



maurey

Hi-Q® cast iron variable pitch sheaves

- Permits Variation of as much as 30% in speed when used with sheaves of fixed diameter



- Hassle free adjustment is allowed by Maurey's patented (#3,661,023) internal key which locks down on the flats in the threads by simply torquing down the setscrew (Type "S" has no internal key). There is no need to remove parts.



- Available in package quantities for air movement OEM units. Light duty diameter companion sheaves also available (See Section A)

TYPE S -

One setscrew over flat. Machined all over to assure close balance

TYPE M & L -

One setscrew with Maurey patented lock key that allows simple adjustment to stationary pulley. All components individually balanced before assembly to assure close balancing tolerances

SINGLE GROOVE VARIABLE PITCH SHEAVES											
O.D. Diameter Inches	Part Number	Type	STOCK BORES MARKED X							Overall Width Inches	Approx Weight Lbs
			1/2	5/8	3/4	7/8	1	1-1/8	1-3/8		
3.25	8325	S	X	X	X					1-3/4	1.3
3.25	8325	M*				X	X	X		1-3/4	1.8
3.75	8350	M*				X	X	X		1-3/4	2.2
4.15	8400	M				X	X	X		1-3/4	2.6
4.75	8450	M				X	X	X		1-3/4	3.0
5.35	8550	M				X	X	X		1-3/4	4.0
6.00	8575	L				X		X	X	1-3/4	4.2
6.00	8600	M		X	X	X	X	X		1-3/4	4.4
6.00	8600	L							X	1-3/4	5.5
6.75	8670	M			X	X	X	X		1-3/4	6.3
6.75	8670	L							X	1-3/4	6.3
7.37	8740	M				X	X	X		1-3/4	7.2
7.37	8740	L							X	1-3/4	7.2

Dimensions Held to commercially acceptable tolerances

For Std. Keyway Dimensions Refer to Chart in Section A

* - Two Setscrews 180 Degrees Apart Over Flats In Place of Integral Locking Key

SINGLE GROOVE VARIABLE PITCH SHEAVES													
PART NUMBER	TYPE	PITCH DIAMETER AND PITCH RANGE											
		3L BELTS				"A" HY-T "AX" TORQUE-FLEX				"B" HY-T "BX" TORQUE FLEX			
		MIN PITCH	TURNS OPEN	MAX PITCH	TURNS OPEN	MIN PITCH	TURNS OPEN	MAX PITCH	TURNS OPEN	MIN PITCH	TURNS OPEN	MAX PITCH	TURNS OPEN
8250	S	1.6	4	2.4	0								
8325	S	2.2	4	3.0	0	2.4	5	3.4	0				
8325	M	2.2	4	3.0	0	2.8	4	3.4	0				
8350	S & M	2.7	4	3.5	0	2.9	5	3.9	0	3.0	7	4.0	2
8400	S & M	3.1	4	3.9	0	3.3	5	4.3	0	3.4	7	4.4	2
8450	S & M	3.7	4	4.5	0	3.9	5	4.9	0	4.0	7	5.0	2
8550	S & M	4.3	4	5.1	0	4.5	5	5.5	0	4.6	7	5.6	2
8575	L	4.3	4	5.1	0	4.6	5	5.6	0	4.6	7	6.0	2
8600	M & L	4.9	4	5.7	0	5.2	5	6.2	0	5.3	7	6.3	2
8670	M & L					5.9	5	6.9	0	6.0	7	7.0	2
8740	M & L					6.5	5	7.5	0	6.6	7	7.6	2



maurey Hi-Q® cast iron variable pitch sheaves



- Cast iron construction. All cast iron sheaves are zinc phosphated for rust resistance
- When ordering variable pitch sheaves, specify bore with part number. For example: D8325 x 5/8"
- Horsepower Ratings
TYPE S - Fractional H.P.
TYPE M & L - Up to and including 10 H.P. per groove

TYPE S - One setscrew over flat. Machined all over to assure close balance
 TYPE M & L - One setscrew with Maurey patented lock key that allows simple adjustment to stationary pulley. All components individually balanced before assembly to assure close balancing tolerances

TWO GROOVE VARIABLE PITCH SHEAVES												
O.D. Diameter Inches	Part Number	Type	STOCK BORES MARKED X								Overall Width Inches	Approx Weight Lbs
			1/2	5/8	3/4	7/8	1	1-1/8	1-3/8	1-5/8 *		
3.25	D8325	M*	X	X	X	X	X	X			3	3.3
3.75	D8350	M*		X	X	X	X	X			3	4.1
4.15	D8400	M		X	X	X	X	X			3-3/8	5.1
4.75	D8450	M		X	X	X	X	X			3-3/8	6.0
5.35	D8550	M		X	X	X	X	X			3-3/8	7.0
5.35	D8550	L							X	X	3-3/8	8.5
6.00	D8575	L				X		X	X	X	3-3/8	8.7
6.00	D8600	M			X	X	X	X			3-3/8	8.7
6.00	D8600	L							X	X	3-3/8	10.1
6.75	D8670	M			X	X	X	X			3-3/8	12.4
6.75	D8670	L							X	X	3-3/8	12.4
7.35	D8740	M			X	X	X	X			3-3/8	14.8
7.35	D8740	L							X	X	3-3/8	14.8

* Two Setscrews 180 Degrees Apart Over Flats In place of Integral Locking Key

Dimensions Held to commercially acceptable tolerances

▲ For Std Keyway Dimensions See Chart in Section A

- Shallow keyseat 3/8" x 1/16". A 3/8" x 1/4" key is furnished.

TWO GROOVE VARIABLE PITCH SHEAVES													
PART NUMBER	TYPE	PITCH DIAMETER AND PITCH RANGE											
		3L BELTS				"A" HY-T "AX" TORQUE-FLEX				"B" HY-T "BX" TORQUE FLEX			
		MIN PITCH	TURNS OPEN	MAX PITCH	TURNS OPEN	MIN PITCH	TURNS OPEN	MAX PITCH	TURNS OPEN	MIN PITCH	TURNS OPEN	MAX PITCH	TURNS OPEN
D8325	M	2.2	4	3.0	0	2.8	4	3.4	0				
D8350	M	2.7	4	3.5	0	2.9	5	3.9	0	3.0	7	4.0	2
D8400	M	3.1	4	3.9	0	3.3	5	4.3	0	3.4	7	4.4	2
D8450	M	3.7	4	4.5	0	3.9	5	4.9	0	4.0	7	5.0	2
D8550	M & L					4.5	5	5.5	0	4.6	7	5.6	2
D8575	L					4.8	5	5.8	0	4.9	7	6.3	2
D8600	M & L					5.2	5	6.2	0	5.3	7	6.3	2
D8670	M & L					5.9	5	6.9	0	6.0	7	7.0	2
D8740	M & L					6.5	5	7.5	0	6.6	7	7.6	2

SINGLE GROOVE VARIABLE PITCH INSTALLATION INSTRUCTIONS

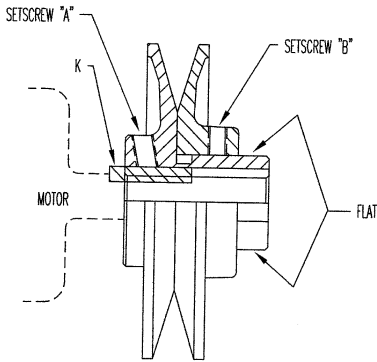

**DO NOT OPERATE
SHEAVE WITH FLANGE
END PROTRUDING
BEYOND STEM**

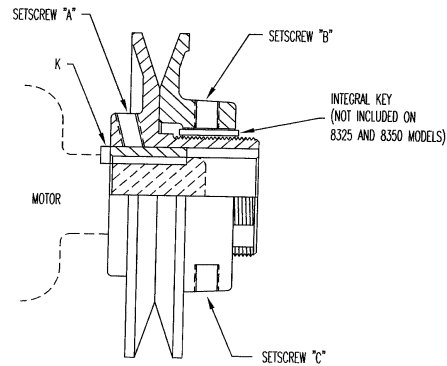

STYLE "S"

STYLE "M" AND "L"

MOTOR MUST BE LOCKED OUT AND ALL APPLICABLE SAFETY PRECAUTIONS MUST BE FOLLOWED WHEN ADJUSTING DRIVE.

Place sheave on shaft with hub (body) side towards the motor. Place keystock "K" (not provided unless a rectangular key is required) in keyseat between shaft and bore of body. (Note: 1/2 inch bores do not have keyslots).

Align shafts and drive and lock variable pitch sheave on shaft using setscrew "A". Use between 135 in-lbs and 150 in-lbs of torque. **NOTE: Using higher than recommended installation torque may cause damage to the sheave.**

Loosen setscrew "B" (and "C" if available) and adjust sheave to desired pitch by opening the appropriate number of turns from the first flat after the full closed position. **NOTE: Each turn changes the pitch line by 0.5 inch.**

- 4.1. On style "S" sheaves, visually locate the setscrew "B" over the flat on the body stem. Lock the setscrew down using between 135 in-lbs and 150 in-lbs of torque.
- 4.2. On 8325 & 8350 "M" style sheaves, locate either setscrew "B" or "C" over the flat on the body stem. Lock both setscrews down using between 135 in-lbs and 150 in-lbs of torque.
- 4.3. On 8400 and larger "M" and "L" style sheaves, locate Maurey Integral Quick Key over the flat (TIP keep finger on key while adjusting it to feel it seat on flat). Lock down using between 135 in-lbs and 150 in-lbs of torque. KEY MUST BE LOCKED OVER FLAT FOR PROPER OPERATION.

Place belt over sheaves (DO NOT PRY BELTS OVER SHEAVES). Adjust drive to proper tension. Lock motor in place.

Additional adjustments may be made by loosening the belts and following steps 2 through 5 above.

NOTE: ALL SETCREWS MUST BE LOCKED IN PLACE PRIOR TO STARTING THE DRIVE. DAMAGE MAY BE DONE TO SHEAVES AND EQUIPMENT IF SETCREWS ARE NOT PROPERLY LOCKED IN PLACE. ADDITIONAL DRIVE AND SETSCREW TIGHTENING SHOULD BE PERFORMED AFTER TWENTY-FOUR HOURS OF OPERATION.

OUTER DIA.	PART NO.	STYLE	BORES
2.50	8250	S	1/2, 5/8, 3/4
3.25	8325	S	1/2, 5/8, 3/4
3.25	8325	M	7/8, 1, 1-1/8
3.75	8350	S	1/2, 5/8, 3/4
3.75	8350	M	7/8, 1, 1-1/8
4.15	8400	S	1/2, 5/8, 3/4
4.15	8400	M	7/8, 1, 1-1/8
4.75	8450	S	1/2, 5/8, 3/4
4.75	8450	M	7/8, 1, 1-1/8
5.35	8550	S	5/8, 3/4
5.35	8550	M	7/8, 1, 1-1/8
6.00	8575	M	7/8, 1-1/8, 1-3/8
6.00	8600	M	5/8, 3/4, 7/8, 1, 1-1/8
6.00	8600	L	1-3/8
6.75	8670	M	3/4, 7/8, 1, 1-1/8
6.75	8670	L	1-3/8
7.37	8740	M	3/4, 7/8, 1, 1-1/8
7.37	8740	L	1-3/8

DOUBLE GROOVE VARIABLE PITCH INSTALLATION INSTRUCTIONS

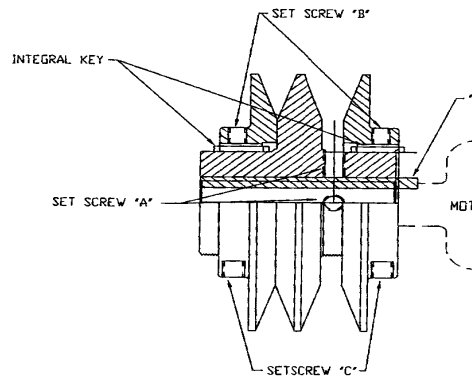

STYLE "M" AND "L"

**DO NOT OPERATE
SHEAVE WITH FLANGE
END PORTRUDING
BEYOND BODY STEM**

1. MOTOR MUST BE LOCKED OUT AND ALL APPLICABLE SAFETY PRECAUTIONS MUST BE FOLLOWED WHEN ADJUSTING DRIVE.
2. Place sheave on shaft with hub (body) setscrew side towards the motor (setscrew on body between flange and center piece). Place keystock "K" (not provided unless a rectangular key is required) in keyseat between shaft and bore of body. (Note: 1/2 inch bores do not have keyways).
3. Align shafts and drive and lock variable pitch sheave on shaft using setscrews "A". Use between 135 in-lbs and 150 in-lbs of torque. **NOTE: Using higher than recommended installation torque may cause damage to the sheave.**
4. Loosen setscrew "B" (and "C" if available) and adjust sheave flange to desired pitch by opening the appropriate number of turns from the first flat after the full closed position. Each turn changes the pitch line by 0.5 inch. **Front and back side flange setscrews may be 180 degrees apart when over first flat and in final locking position.**
 - 4.1 On D8325 & D8350 model sheaves, visually locate the setscrew "B" over the flat on the body stem. Lock the setscrews "B" AND "C" down using between 135 in-lbs and 150 in-lbs of torque.
 - 4.2 On all other model sheaves, locate Maurey Integral Quick Key over the flat (TIP keep finger on key while adjusting it to feel it seat on flat). Lock down using between 135 in-lbs and 150 in-lbs of torque. **KEY MUST BE LOCKED OVER FLAT FOR PROPER OPERATION.**

Place belt over sheaves (DO NOT PRY BELTS OVER SHEAVES). Adjust drive to proper tension. Lock motor in place. Additional adjustments may be made by loosening the belts and following steps 2 through 5 above.

NOTE: ALL SETSCREWS MUST BE LOCKED IN PLACE PRIOR TO STARTING THE DRIVE. DAMAGE MAY BE DONE TO SHEAVES AND EQUIPMENT IF SETSCREWS ARE NOT PROPERLY LOCKED IN PLACE. ADDITIONAL DRIVE AND SETSCREW TIGHTENING SHOULD BE PERFORMED AFTER TWENTY-FOUR HOURS OF OPERATION.

TIP: IF ONE BELT APPEARS LOOSE, REMOVE TENSION FROM THE DRIVE AND ADJUST LOOSE SIDE FLANGE BY ONE HALF TURN.

OUTER DIA.	PART NO.	STYLE	BORES
3.25	D8325	M	1/2, 5/8, 3/4, 7/8, 1, 1-1/8
3.75	D8350	M	5/8, 3/4, 7/8, 1, 1-1/8
4.15	D8400	M	5/8, 3/4, 7/8, 1, 1-1/8
4.75	D8450	M	5/8, 3/4, 7/8, 1, 1-1/8
5.35	D8550	M	5/8, 3/4, 7/8, 1, 1-1/8
5.35	D8550	L	1-3/8, 1-5/8
6.00	D8575	L	7/8, 1-1/8, 1-3/8, 1-5/8
6.00	D8600	M	3/4, 7/8, 1, 1-1/8
6.00	D8600	L	1-3/8, 1-5/8
6.75	D8670	M	3/4, 7/8, 1, 1-1/8
6.75	D8670	L	1-3/8, 1-5/8
7.35	D8740	M	3/4, 7/8, 1, 1-1/8
7.35	D8740	L	1-3/8, 1-5/8